

INSTALLATION INSTRUCTIONS

EQUIPMENT REQUIRED: SCREWDRIVER, FISHWIRE

WIRING ACCESS LOCATION:

DRILL BITS: 1/2

HITCH REQUIRES 1/2" PIN AND CLIP

WRENCHES: (TIGHTEN ALL FASTENERS WITH TORQUE WRENCH) 3/4, 7/8

VEHICLE

CHEVROLET AVEO 5 DOOR
PONTIAC WAVE & G3 WAVE 5 DOOR
SUZUKI SWIFT+ 5 DOOR

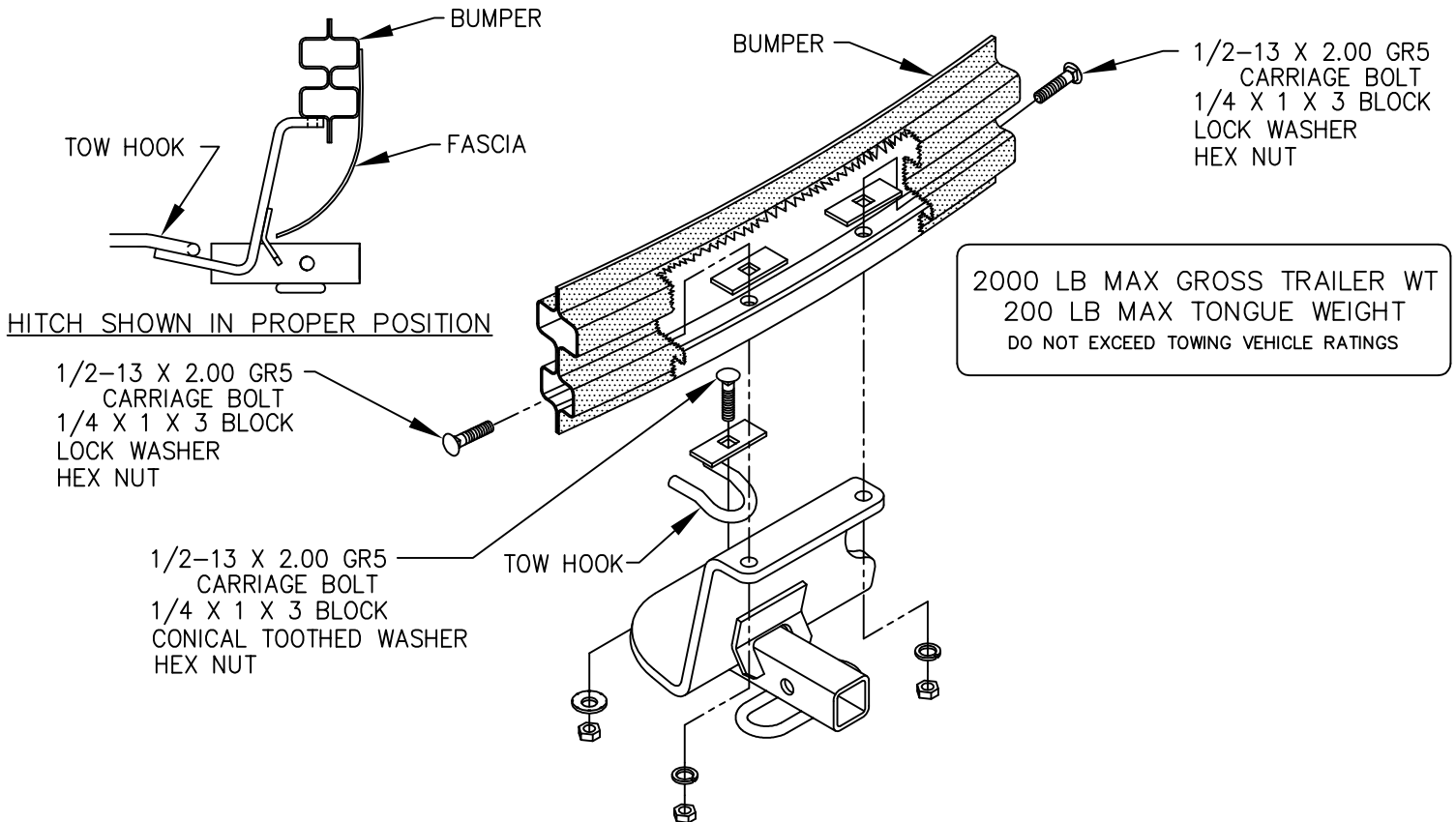

1. RAISE HITCH INTO POSITION AND SECURELY INSTALL TOW HOOK ATTACHMENT USING CARRIAGE BOLT, BLOCK CONICAL TOOTHED WASHER AND HEX NUT.
2. REMOVE BOTTOM REAR FASCIA SCREWS TO ALLOW FOR DRILL ACCESS THROUGH THE REAR HOLES OF THE HITCH AND INTO THE BUMPER.
3. ROTATE THE HITCH SO THAT IT IS CENTERED ON THE VEHICLE AND DRILL 1/2 INCH DIA. HOLES.
4. FISHWIRE CARRIAGE BOLTS AND BLOCKS THROUGH THE ENDS OF THE BUMPER AND THROUGH THE DRILLED HOLES.
5. INSTALL LOCK WASHERS AND HEX NUTS TO THE CARRIAGE BOLTS FISHWIRED THROUGH THE BUMPER.
6. REINSTALL FASCIA SCREWS REMOVED IN STEP 2 AND TIGHTEN ALL FASTENERS.

TIGHTEN ALL 1/2 GR5 FASTENERS TO 75 LB.-FT.

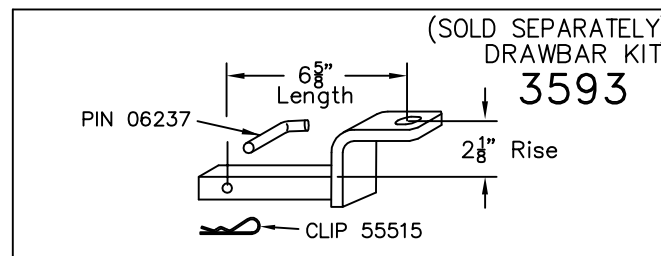

USE ONLY THE DRAWBAR SHOWN FOR CORRECT BUMPER CLEARANCE AND HEIGHT.
DRAWBAR MUST BE USED IN THE RISE POSITION ONLY.

THIS PRODUCT COMPLIES WITH SAFETY SPECIFICATIONS AND REQUIREMENTS FOR CONNECTING DEVICES AND TOWING SYSTEMS OF THE STATE OF NEW YORK, V.E.S.C. REGULATION V-5 AND SAE J684.

APPROX WEIGHT (LB.)	FASTENER KIT
14	24741F

NOTE: Check hitch frequently, making sure all fasteners and ball are properly tightened. If hitch is removed, plug all holes in trunk pan or other body panels to prevent entry of water and exhaust fumes. A hitch or ball which has been damaged should be removed and replaced. Observe safety precautions when working beneath a vehicle and wear eye protection. Follow car maker's specs for maximum trailer weight and tongue weight. Do not cut access or attachment holes with a torch.

TOWING PRODUCTS
Plymouth, Michigan