

AFTERMARKET MANUAL

HELUX PIN BOX

NOTICE BEFORE PURCHASE/INSTALLATION

Purchase verification required. See instructions below for pin weight measuring process.

Returns will not be accepted once product has been installed.

Purchase Verification

The Curt Helux Pin Box is offered in different pin weight ratings. To accurately order the pin box that supports the weight of your 5th wheel, you will need to know the pin weight. The best way to attain the pin weight is to take your 5th wheel to a certified scale, i.e. CAT Scale.

For additional information, visit <https://catscale.com/how-to-weigh/>.

Note: Be sure your 5th wheel is fully loaded with everything you would normally have when travelling or camping including ATVs, golf cart, motorcycles, snowmobiles, etc.

1. Connect the 5th wheel to the tow vehicle and drive onto the scale; front axle on Scale 1, rear axle on Scale 2 and the trailer axles on Scale 3.
2. Note these weights and total the weights from #1 and #2.
3. Disconnect the 5th wheel and reweigh just the tow vehicle on scales #1 and #2.
4. Note these weights and total the weights from #1 and #2.
5. Subtract the weight total in step 4 from the weight total in step 2 to find the actual hitch weight.

Pin weight can also be approximated by multiplying the GVWR of the 5th wheel by 22% (0.22). This weight result will provide you with approximate pin weight to match with the chart below. Depending on actual trailer weight and load distribution, approximate weight could vary from actual weight. For best results, getting the actual weight is preferred.

Step 1

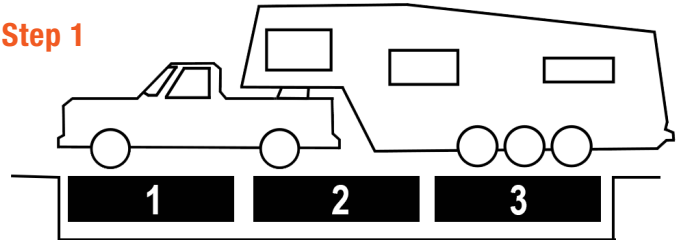

Step 2: Scale #1 + Scale #2 = A

Step 3

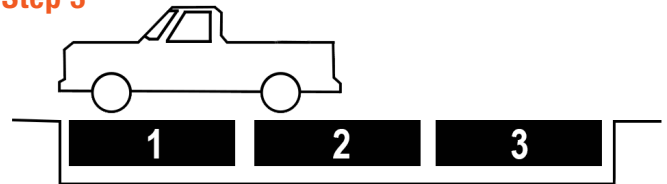

Step 4: Scale #1 + Scale #2 = B

Step 5: A - B = Pin Weight

Weight Carrying Capacity - Helux Pin Box Kits

Pin Weight Calculated, see Purchase Verification

Part Number	Spring Rating (lb.)	Pin Weight ¹ (Loaded - lb.)	Min. Pin Weight ²	Max. Pin Weight ³
2024044570	1,800	3,713 - 4,332	2570	4850
2024044571	2,000	4,333 - 4,900	2860	5400
2024044572	2,300	4,901 - 6,000	3290	6200

¹Optimal pin weight value range when choosing a Curt Helux pin box.

²Unloaded - No cargo and empty fresh, black, and gray water tanks.

³Loaded - Cargo loaded including toy hauler area, tanks travel-ready.

Note: The Curt Helux Pin Box models are determined by the weight rating of the spring used between the upper and lower jaws.

Product Photo



⚠ WARNING

Never exceed the vehicle manufacturer's recommended towing capacity.

Mount the Curt Helux pin box with the new hardware included in the kit. Do not reuse the mounting hardware from the previous pin box.

Product Registration and Warranty

CURT stands behind our products with industry-leading warranties. To get copies of the product warranties, register your purchase or provide feedback, visit: warranty.curtgroup.com/surveys

Level of Difficulty

Moderate

Installation difficulty levels are based on time and effort involved and may vary depending on the installer level of expertise, condition of the vehicle, and proper tools and equipment.

Tools Required

SAE socket set	SAE wrenches
Tape measure	Box-end wrench set
Safety glasses	Air compressor
Level	--

SAFETY INSTRUCTIONS

Safety glasses should be worn at all times while installing this product.

NOTICE

Before you begin installation, read all instructions thoroughly.

Proper tools will improve the quality of installation and reduce the time required.

This installation requires:

Two or three people to help support the weight of the pin box as it is being lifted.

To help prevent damage to the product or vehicle, refer to the torque requirements when securing hardware during the installation process.

ASSEMBLY

Parts List

#	Qty	Description
1	1	Pin box assembly
2	10	Hex bolt, 5/8"-11 x 1 3/4", grade 5
3	10	Serrated-flange nut 5/8"-11, grade 5

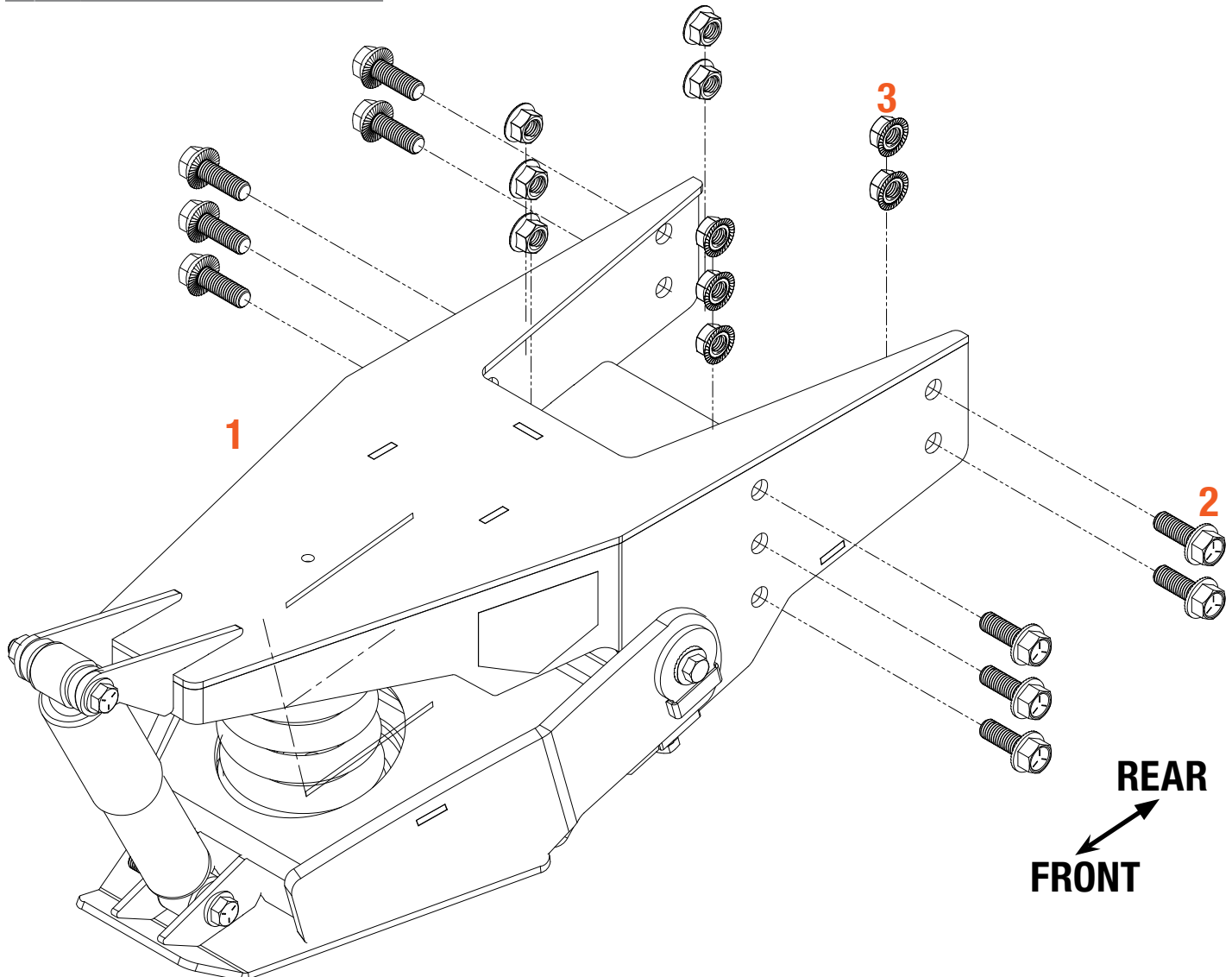

INSTALLATION

⚠ WARNING

An unsupported pin box during product removal can result in death, serious personal injury, severe product and/or property damage. Properly support pin box throughout installation.

NOTICE

The pin box assembly weighs several hundred pounds. Installation and removal of pin boxes requires a minimum of two people. A forklift may be used to lift the pin box into position.

The 5th wheel should always be towed while level. Adjustment of the pin box mounting height, the tow vehicle height or suspension may be necessary to accomplish a level towing condition.

Step 1

Level the trailer front-to-back and measure from the ground to the bottom of the kingpin plate on the current pin box.

Record this as dimension A. This dimension will be used to install the new pin box at the proper height.

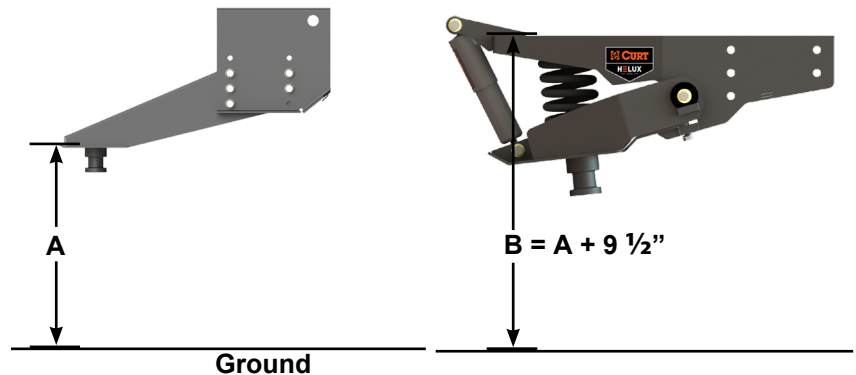

Step 2

Properly support pin box before removing mounting bolts.

⚠ WARNING

An unsupported pin box during product removal can result in death, serious personal injury, severe product and/or property damage.

Remove the fasteners securing the old pin box and carefully lower it to the ground.

Note: The Helux pin box kit includes new mounting hardware. Do not reuse the mounting hardware from the previous pin box.

Mount the Curt Helux pin box with the new hardware included in the kit.

Step 3

Lift the new pin box and support it while positioning it at the appropriate height.

Measure from the ground up to the flat plate of the upper jaw on the Helux pin box. Adjust the pin box height until it is equal to dimension A recorded in step 1 plus 9-1/2\".

Once the pin box is appropriately positioned, secure it with the supplied hardware kit. Use an equal number of fasteners as were previously used.

Torque 5/8" bolts to 120 ft-lb±5 lb.

HITCHING & PULL TEST

⚠ WARNING

Failure to follow hitching instructions may result in death or serious injury.

NOTICE

Note: Be sure to consult your hitch manufacturer's owner's manual for proper hitching procedure.

Step 1

Place chocks firmly against the front and rear of each trailer tire to prevent movement, either forward or backward. If necessary, lower the tow vehicle's tailgate to allow the pin box to clear.

Note: The clearance of the lowered tailgate to the trailer needs to be monitored during hookups, since some combinations of truck and trailer have little or no clearance.

Step 2

Using the trailer landing gear, adjust trailer height per the manufacturer's recommendation so the bottom of the trailer's pin box is 1/2" to 1" **below** the hitch skid plate.

⚠ WARNING

Failure to follow these instructions may result in the kingpin being too high and coming to rest on top of closed jaws or not completely inside the jaw. This could result in the trailer separating from the hitch which may result in death or serious injury.

⚠ WARNING

Do not attempt to hitch the trailer by using trailer jacks to lower the trailer and kingpin. This could result in the kingpin coming to rest on top of the skid plate instead of within the hitch opening, which may result in death or serious injury.

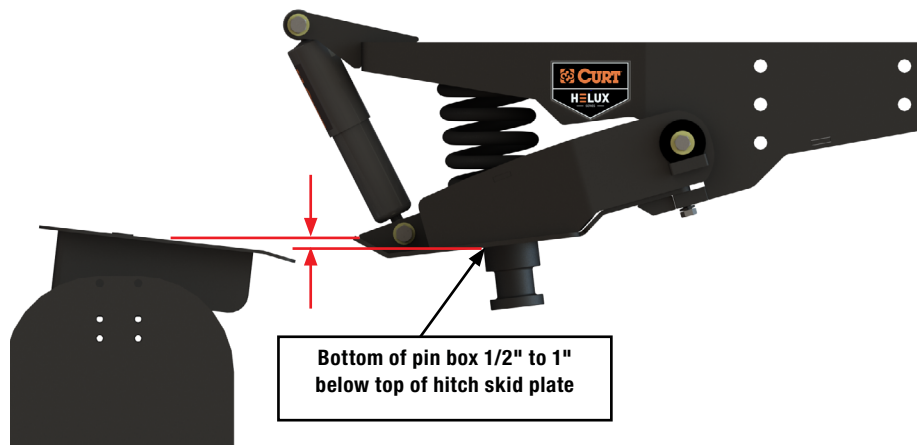

Step 3

Back the truck slowly toward the trailer until the truck's hitch contacts the bottom of the pin box and the kingpin slides into the receiver.

Note: During the hitching maneuver, the bottom of the trailer's pin box should come into contact with the hitch skid plate ramp.

Latch the 5th wheel hitch in closed position per the instructions of the 5th wheel hitch manufacturer.

⚠ WARNING

Failure to perform a pull test may result in severe property damage, serious personal injury or death. Failure to secure the tow vehicle and trailer from movement during procedure could result in severe property damage, serious personal injury or death.

Step 4

Securely chock the trailer tires. The trailer landing gear should be firmly on the ground to support the trailer, and the tow vehicle must be in park with the emergency brake engaged.

Note: Make sure tow vehicle and trailer are properly secured against movement during the procedure.

Step 5

Return to the cab of the tow vehicle, release the emergency brake and then apply the trailer brakes.

Step 6

Slowly pull the trailer forward with the tow vehicle.

If the tow vehicle is properly hitched, the wheel blocks and trailer brakes should keep the truck from moving forward.

If the trailer is not properly hitched, the trailer will separate from the hitch and the truck will move forward while leaving the trailer behind.

Note: If the trailer separates from the tow vehicle, repeat the hitching procedure.

Step 7

After successfully performing the Pull Test, fully raise the landing gear per manufacturer's recommendations.

Step 8

Check and inspect all electrical circuits for proper operation, including clearance lights, turn signals and stop lights.

Step 9

Remove and store all trailer wheel blocks.

TROUBLESHOOTING & MAINTENANCE

What is happening	What should be done
Trailer not level	Adjust pin box or hitch accordingly.
Excessive chucking in tow vehicle	Inspect pin box coil spring for condition and any possible damage. Be sure cargo is balanced from side to side and front to back.
Excessive noise from pin box area	Verify that the pin box is securely attached to the 5th wheel. If the king pin is excessively worn, the jaw plate will need to be replaced. Check the condition of the coil spring and replace if damaged or broken. Look for damage on shock or a disconnected shock. Reconnect or replace shock if needed. Hitch mechanisms can also cause noise. Verify that unwanted noise is not coming from the hitch. The hitch manufacturer can provide guidelines for this check.
Pinbox too far open (hitch plate tilted toward the cab of the truck) when the trailer is unloaded.	Observe the pinbox and hitch plate once the trailer is loaded. The pinbox will close down as the unit is loaded to the proper pin weight.

For Service Manual, Replaceable Parts and Additional Troubleshooting

Scan the QR code:



Maintenance

Always check pin box and its components for damage or any loose nuts and bolts.

Be sure the trailer pulls in a level condition before traveling.

